

KRM

BOTEX



BUILT IN BRITAIN
...for professionals!



High capacity self-loading cranes

Save time AND money!

- * NO telehandler
- * NO low loader
- * NO waiting around
- * NO extra machinery or labour costs



**One man,
uninterrupted,
operation!**



**Clean and tidy – just
finish last fill and go!**



**Ground conditions less
restrictive – no tracking
during loading when
ground wet!**

**Compact –
parks tidily
for spreading
and transport**



**See reverse
for technical
specifications**





PRODUCT DETAILS FOR BOTEX TL LOADERS

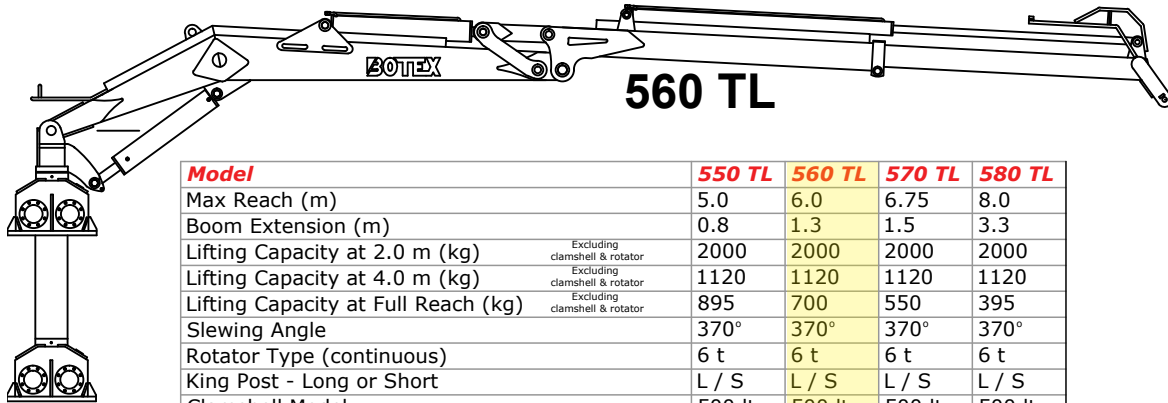

Model	550 TL	560 TL	570 TL	580 TL
Max Reach (m)	5.0	6.0	6.75	8.0
Boom Extension (m)	0.8	1.3	1.5	3.3
Lifting Capacity at 2.0 m (kg)	2000	2000	2000	2000
Lifting Capacity at 4.0 m (kg)	1120	1120	1120	1120
Lifting Capacity at Full Reach (kg)	895	700	550	395
Slewing Angle	370°	370°	370°	370°
Rotator Type (continuous)	6 t	6 t	6 t	6 t
King Post - Long or Short	L / S	L / S	L / S	L / S
Clamshell Model	500 ltr	500 ltr	500 ltr	500 ltr
Weight of Grapple & Rotator (kg)	180	180	180	180
Gross Slewing Torque (kNm)	14.3	14.3	14.3	14.3

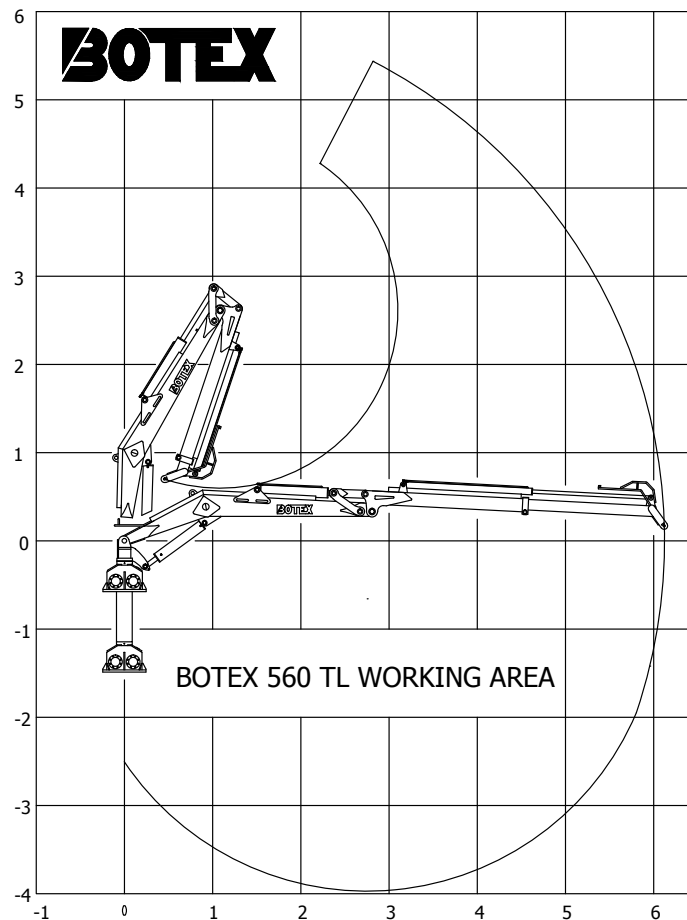

Keith Rennie Machinery Ltd

info@krm-ltd.co.uk

Tel: 01423 324221

www.krm-ltd.co.uk